

Installation manual

AQ4 Horizontal Vent Kit

For Bosch AquaStar Models: GWH 1600 P, GWH 1600 H

For Bosch ProTankless Models: GWH 425 PN, GWH 425 HN*



BOSCH

WARNING: If the information in this manual is not followed exactly, a fire or explosion may result causing property damage, personal injury or death. Do not store or use gasoline or other flammable vapor and liquids in the vicinity of this or any other appliance.

Improper installation, adjustment, alteration, service or maintenance can cause injury or property damage. Refer to this manual. For assistance or additional information consult a qualified installer, service agency or the gas supplier.

In the Commonwealth of Massachusetts this product must be installed by a licensed plumber or gas fitter.

Upon completion of the installation, these instructions should be handed to the user of the appliance for future reference.

* The GWH 425 HN has been redesigned. This vent kit is not compatible with the older version (identified by a white cover). Use the AQ1 horizontal vent kit with the older version.



Table of Contents

1 Introduction	3
1.1 Parts included	3
1.2 Warnings	3
1.3 Preparation	3
1.4 Requirements for installation in Massachusetts	4
2 AQ4 Installation instructions	5
2.1 Introduction	5
2.2 Locating power vent hood and clearances	5
2.3 Power vent hood	5
2.4 Power vent motor	6
2.5 Vent piping	7
2.6 Linear safety spillage switch	7
2.7 Flow switch	8
3 Operation	9
3.1 First time start up	9
4 Maintenance	9
5 Troubleshooting	9
5.1 Introduction	9
5.2 Power vent motor runs all the time or intermittently without water flow	9
5.3 Pilot will not hold when lit or spark automatically with hot water flow	10
5.4 Sparks but pilot will not light	10
5.5 Pilot goes out during hot water use	10
5.6 Noise when power vent motor is running	10
6 One Year Limited Warranty	11
7 Wiring diagram	12
8 Vent hood template	13

1 Introduction

1.1 Parts included

Vent Hood Kit

- 1 - 4" vent hood: VH1-4
- 4 - Exterior screws
- 1 - 5" to 4" vent reducer pipe
- 1 - AQ4FLAPPER back draft accessory

Vibration Mount Packet

- 2 - Vibration mounts with nuts and washers
- 2 - Brackets with nuts and washers

Flow Switch Packet

- 1 - Flow switch
- 4 - Replacement pipes (See chapter 2.7)
- 2 - Pipe clips
- 1 - Molex connector cable
- 1 - Heat exchanger bushing

Power vent motor

- 1 - Power vent motor (HSUL-1 Series containing integrated 24v control circuit) including 25 foot control cable with wire nuts and an HPN 6-foot power cord
- 5 - Nylon ties

1.2 Warnings

1. Failure to install, maintain and/or operate the power vent in accordance with manufacturer's instructions may result in conditions which can produce bodily injury and property damage.
2. The power vent must be installed by a qualified installer in accordance with all local codes or, in their absence, in accordance with the National Fuel Gas Code (ANSI Z223.1 NFPA #54), the National Electric Code, the Canadian Electrical Code (C22.1), Canadian Gas Code (CSA B149.1) and The Occupational Health and Safety Act (OSHA) as applicable.
3. The power vent motor shaft must be mounted horizontally to prevent motor bearing wear.
4. Disconnect power supply when making wiring connections or when working around the fan blade and motor. Failure to do so may result in severe personal injury and equipment damage.
5. Make certain the power source is adequate for the fan motor requirements. Do not add the power vent to a circuit where the total load is unknown.
AQ4 Motor is 200 watts- 1.66 amps @ 120vac.
6. Locate the outlet receptacle as close to the vent motor as possible. Do not use an extension cord.



Warning: Failure to install AQ4FLAPPER properly may allow freezing air to come in contact with the water heater's heat exchanger and cause the heat exchanger to burst. Such damage is not covered under the water heater's warranty.

1.3 Preparation

1. Follow installation and operating instructions manual supplied with the water heater.
2. Before mounting water heater to wall, check its minimum clearance requirements.
3. When using an AQ4 the maximum vent length from the water heater to the point of termination is 25 feet with one elbow. Subtract 5 feet for each additional 90° elbow (up to two additional elbows allowed.)
4. Install power vent motor as close to the vent hood

as possible.

1.4 Requirements for installation in Massachusetts

Attention residents of the Commonwealth of Massachusetts:

In the Commonwealth of Massachusetts the following regulation went into effect on 12/30/2005:

(a) For all side wall horizontally vented gas fueled equipment installed in every dwelling, building or structure used in whole or in part for residential purposes, including those owned or operated by the Commonwealth and where the side wall exhaust vent termination is less than seven (7) feet above finished grade in the area of the venting, including but not limited to decks and porches, the following requirements shall be satisfied:

1. **INSTALLATION OF CARBON MONOXIDE DETECTORS.** At the time of installation of the side wall horizontally vented gas-fueled equipment, the installing plumber or gasfitter shall observe that a hard wired carbon monoxide detector with an alarm and battery back-up is installed on the floor level where the gas equipment is to be installed. In addition, the installing plumber or gasfitter shall observe that a battery operated or hard wired carbon monoxide detector with an alarm is installed on each additional level of the dwelling, building or structure served by the side wall horizontally vented gas-fueled equipment. It shall be the responsibility of the property owner to secure the services of qualified licensed professionals for the installation of hard wired carbon monoxide detectors.
 - a. In the event that the side wall horizontally vented gas-fueled equipment is installed in a crawl space or an attic, the hard wired carbon monoxide detector with alarm and battery back-up may be installed on the next adjacent floor level.
 - b. In the event that the requirements of this subdivision can not be met at the time of completion of installation, the owner shall have a period of thirty (30) days to comply with the above requirements; provided, however, that during said thirty (30) day period, a battery operated carbon monoxide detector with an alarm shall be installed.
2. **APPROVED CARBON MONOXIDE DETECTORS.** Each carbon monoxide detector as required in accordance with the above provisions shall comply with NFPA 720 and be ANSI/UL 2034 listed and IAS certified.
3. **SIGNAGE.** A metal or plastic identification plate shall be permanently mounted to the exterior of

the building at a minimum height of eight (8) feet above grade directly in line with the exhaust vent terminal for the horizontally vented gas fueled heating appliance or equipment. The sign shall read, in print size no less than one-half (1/2) inch in size, "GAS VENT DIRECTLY BELOW. KEEP CLEAR OF ALL OBSTRUCTIONS".

4. **INSPECTION.** The state or local gas inspector of the side wall horizontally vented gas fueled equipment shall not approve the installation unless, upon inspection, the inspector observes carbon monoxide detectors and signage installed in accordance with the provisions of 248 CMR 5.08(2)(a)1 through 4.

(b) EXEMPTIONS: The following equipment is exempt from 248 CMR 5.08(2)(a)1 through 4:

1. The equipment listed in Chapter 10 entitled "Equipment Not Required To Be Vented" in the most current edition of NFPA 54 as adopted by the Board; and
2. Product approved side wall horizontally vented gas fueled equipment installed in a room or structure separate from the dwelling, building or structure used in whole or in part for residential purposes.

(c) MANUFACTURERS REQUIREMENTS - GAS EQUIPMENT VENTING SYSTEM REQUIRED.

When the manufacturer of Product Approved side wall horizontally mounted gas equipment provides a venting system design or venting system components with the equipment, the instructions provided by the manufacturer for the installation of the equipment and the venting shall include:

1. Detailed instructions for the installation of the venting system or the venting system components; and
2. A complete parts list for the venting system design or venting system.

(d) MANUFACTURER REQUIREMENTS - GAS EQUIPMENT VENTING SYSTEM NOT PROVIDED.

When the manufacturer of a product approved side wall horizontally vented gas fueled equipment does not provide the parts for the venting of flue gases, but identifies "special venting systems," the following requirements shall be satisfied by the manufacturer:

1. The referenced "special venting system" instructions shall be included with the appliance or equipment installation instructions; and
2. The "special venting systems" shall be product approved by the Board, and the instructions for that system shall include a parts list and detailed installation instructions.

(e) A copy of all installation instructions for all products approved side wall horizontally vented gas fueled equipment, all venting instructions, all parts lists for venting instructions, and/or all venting design instructions shall remain with the appliance or equipment at the completion of the installation.

2 AQ4 Installation instructions

2.1 Introduction

Please follow these instructions. Failure to follow instructions may result in:

- Damage, injury or death
- Improper operation
- Loss of warranty

If you are unable to perform the tasks required to install the water heater and this accessory properly, please contact a locally licensed plumber, HVAC contractor or gas technician.

Please contact Bosch Water Heating with any questions.

2.2 Locating power vent hood and clearances

The maximum vent length from the water heater to the point of termination is 25 feet with one elbow. If using more than one 90° elbow, subtract 5 feet off the maximum vent length for each additional elbow used. Maximum of three elbows allowed.



The power vent motor must be installed as close as possible to the VH1-4 vent hood.

Clearances

The vent system must terminate so that proper clearances from the center of the vent hood (Fig. 1) are maintained as cited in the National Fuel Gas Code, ANSI Z223.1 and CSA B149.1 in Canada:

“The vent terminal shall also not be installed closer than 3 feet from the inside corner of an L-shaped structure, or less than 1 foot above grade or anticipated snow pack level.”

Also:

“The exit terminals of mechanical vent system shall be located not less than 7 feet above grade when located adjacent to a public walkway. The venting system shall terminate at least 3 feet above any forced air inlet within 10 feet. The venting system shall terminate at least 4 feet below, 4 feet horizontally from or 1 foot above any door, window or gravity air inlet into any building.”

2.3 Power vent hood

1. Attach the mounting template (on page 13) to the interior wall that the vent hood will be penetrating.
2. Ensure that the proposed vent termination clearances are met (Chapter 2.2) before cutting opening through wall. Using a 1/2” drill bit, drill two pilot holes where noted on the template. The drill bit must be long enough to penetrate to the building exterior.
3. Attach the template to the outside of the building aligning the pilot holes on the template with the pilot holes drilled in step 2.
4. Using a reciprocating saw, cut a hole through the building siding, wall board, etc., following the appropriate lines of the template.
5. Apply a bead of exterior-rated caulk to the vent hood flange to seal at the exterior of building.
6. Slide the vent hood through the opening and fasten to exterior wall using screws provided.
7. Install backdraft flapper using the instructions included with flapper.

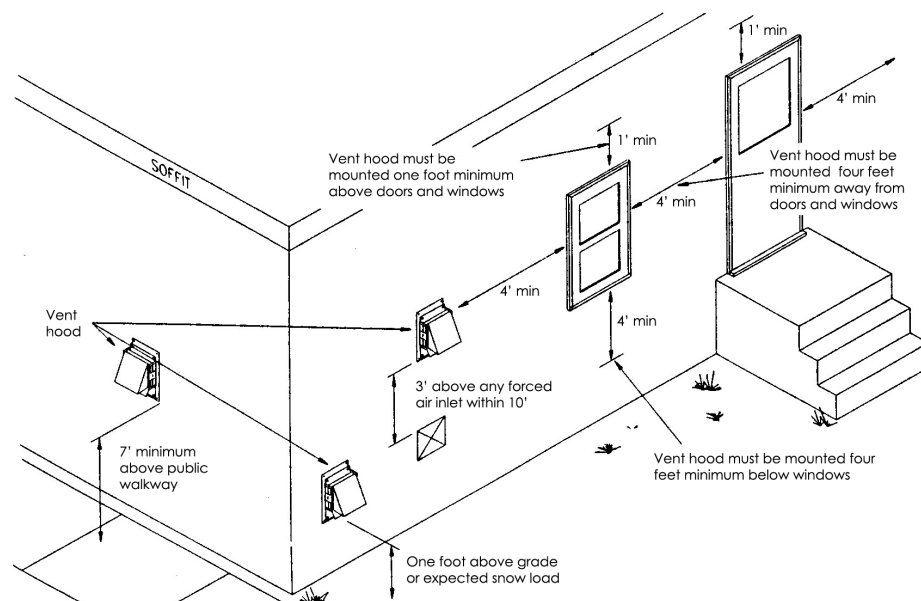

Fig. 1 External vent hood clearances

2.4 Power vent motor



Caution: Power vent motor must be mounted with vibration mounts and with motor shaft horizontal to prevent motor bearing wear.

1. Remove vibration mounts, nuts and washers from parts bag. Install on power vent motor as shown in Fig. 2.
2. To prevent vibration, securely support power vent motor from ceiling or joist using a plumber's strap fastened to the vibration mounts. As an alternative means of support, a wall bracket may be used to support the underside of the motor. Observe a 6" clearance to combustibles on all sides of the power vent motor. (Fig. 3)
3. Connect the power vent motor outlet to the inner sleeve of the vent hood (Fig. 4). Use the four pre-punched holes in the outlet collar of the power vent motor as a guide to drill $\frac{1}{8}$ " diameter holes into the vent pipe. Fasten power vent motor outlet to the vent hood inlet using sheet metal screws. Seal the connection with high temperature silicone sealant.



Note: Any additional vent pipe used between the power vent motor and the vent hood will be under positive pressure during operation. This vent pipe must be single wall galvanized or stainless steel vent pipe. **The connections must be sealed with high temperature silicone sealant when using galvanized or ungasketed stainless steel pipe.**

4. Route the control cable from the power vent motor along the ceiling or joists down to the right side of water heater, taking care not to come within 6" of the vent pipe or any other potentially hot surface. In many cases, the gas or water supply piping can be used as a routing path from the ceiling down to the right side of the water heater. Use the supplied nylon ties to secure the cable.

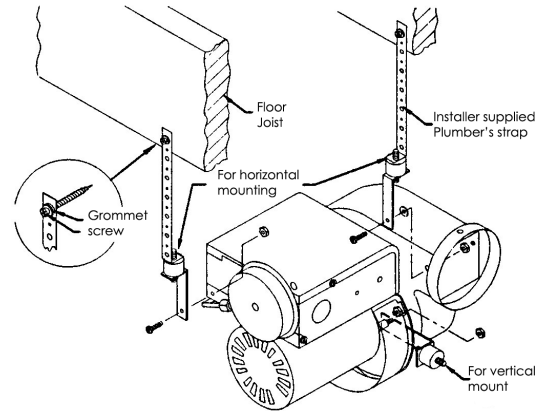

Fig. 2 Vibration mounts and recommended support

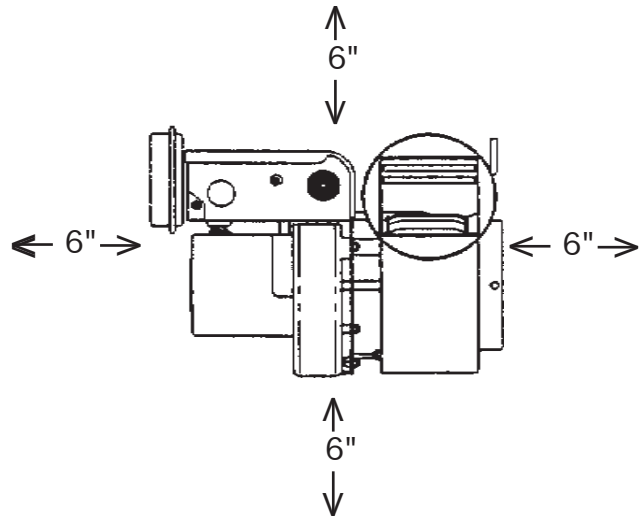

Fig. 3 Minimum clearances to power vent motor

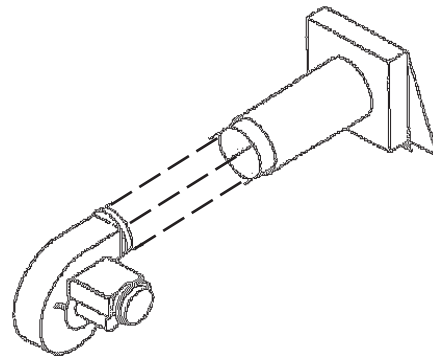

Fig. 4 Vent connection to power vent motor

2.5 Vent piping

1. Install 5" to 4" reducer pipe on top of the water heater and then connect a 4" 90° elbow to begin the horizontal run. Use 4" vent pipe to connect from this elbow to the power vent motor inlet, avoiding elbows when possible. The maximum vent length from the water heater to the point of termination is 25 feet with one elbow. (Fig. 5) If using more than one 90° elbow, subtract 5 feet off the maximum vent length for each additional elbow used. **A maximum of three elbows is allowed. The minimum straight vent length is 2 ft.**
2. Support the vent pipe in accordance with vent pipe manufacturer's instructions. Vent pipe is not supplied in the power vent kit, with the exception of the 5" to 4" reducer in the AQ4 kit. Observe the clearances associated with the class of vent pipe used. 4" single wall galvanized, 4" stainless steel or 4" B-vent pipe is required.

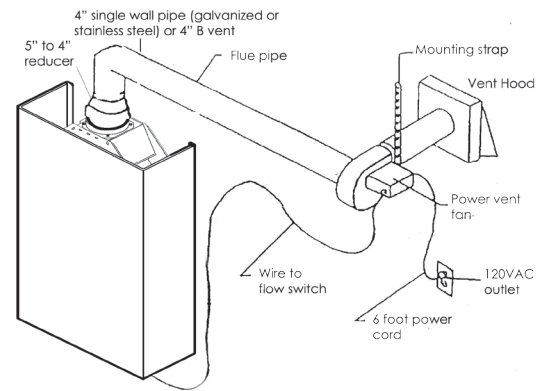

Fig. 5 Venting setup

2.6 Linear safety spillage switch

The linear safety spillage switch provides a means for safety shut down of the water heater in the event of flue blockage or power vent failure. If hot flue gases spill from the draft hood diverter, the draft spillage sensing switch will open the pilot safety circuit and shut off all gas to the water heater. The switch is normally closed and opens at temperatures greater than 185° F. It has a manual reset button.

Mounting the linear safety spillage switch

1. Attach the spillage switch to the top left of the heater's draft diverter using the existing hole and the included mounting screw. (Fig. 6)
2. Lay copper capillary sensing tube across top of the draft diverter. Allow excess tube to hang down right side of heater. Do not cut or crimp capillary tube.
3. Route the two wires from the spillage switch down the left side of heater to the ECO keeping the cables out of contact with hot surfaces. (Fig. 6)

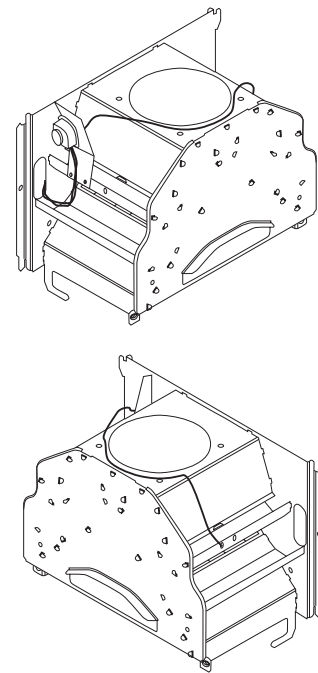

Fig. 6 Linear safety spillage switch mounting

Connecting linear safety spillage switch to pilot safety circuit

The ECO/temperature limiter is mounted on the lower left outlet water pipe. (Fig. 7)

1. Remove one wire lead connected to ECO terminal (it does not matter which one is disconnected).
2. Attach ¼" quick connect terminal end of linear spill switch cable to now exposed terminal of the ECO.
3. Connect the male spade connector to the removed lead wire from step 1. See the wiring diagram in Fig. 13 to confirm proper set up.

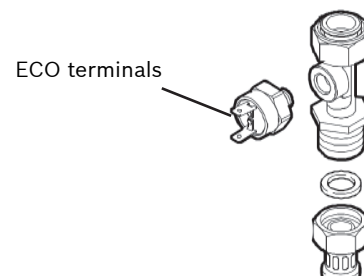

Fig. 7 ECO location

2.7 Flow switch

Replacement piping and flow switch is included for 1600P/425PN and 1600H/425HN water heaters. Check your model number on the right side of the water heater cover to confirm which procedure to follow.

2.7.1 Models 1600P/425PN

1. Shut off cold water supply isolation valve. If none installed, install before proceeding. Open hot water tap to relieve water pressure if water is already connected.
2. Remove and save clip on lower right side of heat exchanger.
3. Using a flat head screw driver remove and save pin from front, right side of water valve. (Fig. 8)
4. Remove copper pipe and set aside.
5. Find and connect the black flow switch to the bushing and pipes shown in Fig. 9A. Secure together with supplied clips.
6. Position flow switch and connecting pipe and bushing in place of the copper pipe that was removed.
7. Reinstall pin in water valve and clip on heat exchanger connection.
8. Connect the three prong Molex connector cable to the flow switch.
9. Connect control cable from vent motor to Molex connector cable with wire nuts as seen in Fig. 10.

2.7.2 Models 1600H/425HN

1. Shut off cold water supply isolation valve. If none installed, install before proceeding. Open hot water tap to relieve water pressure if water is already connected.
2. Remove and save clip on lower right side of hydrogenerator.
3. Remove and save pin from front, right side of water valve using a flat head screwdriver. (Fig. 8)
4. Remove copper pipe and set aside.
5. Find and connect the black flow switch to the pipes shown in Fig. 9B.

Note: There are two pipes included for connection from flow switch to hydro-generator. One is slightly longer than the other. If your water heater's serial number is greater than FD792, you must use the longer pipe for this connection.

6. Position flow switch and connecting pipes in place of the copper pipe that was removed. Secure together with supplied clips.
7. Reinstall pin in water valve and clip on heat exchanger.
8. Connect the three prong Molex connector cable to the flow switch.
9. Connect control cable to Molex connector cable with wire nuts as seen in Fig. 10.

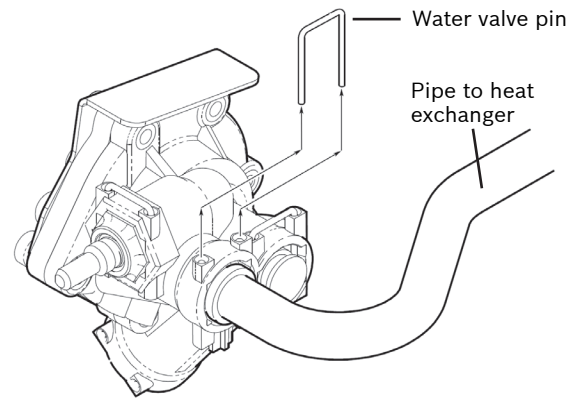

Fig. 8 Water valve pin

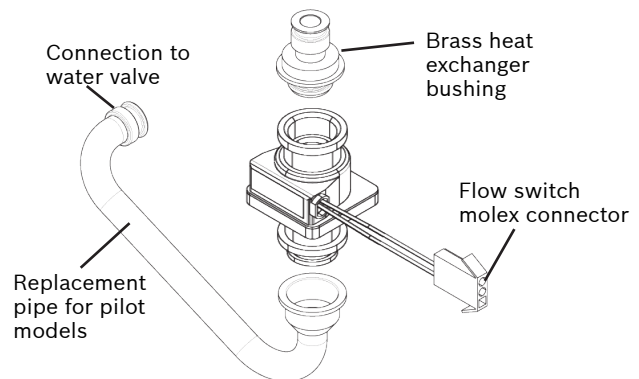

Fig. 9A 1600P/425PN flow switch connections

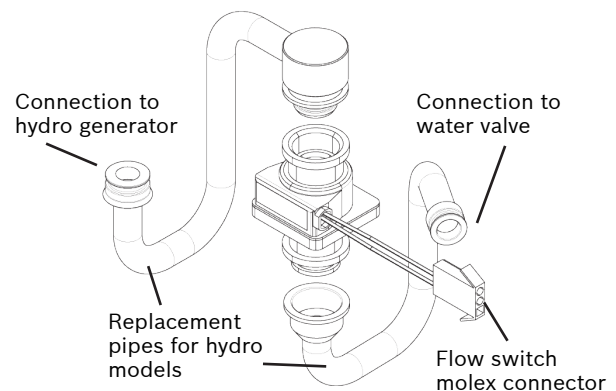

Fig. 9B 1600H/425HN flow switch connections

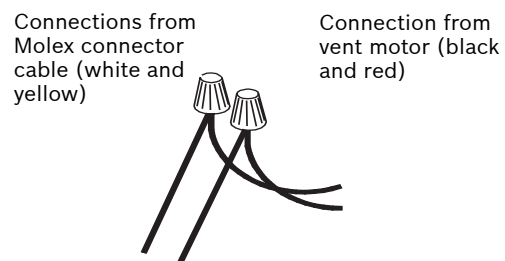

Fig. 10 Flow switch electrical connections

3 Operation

3.1 First time start up

3.1.1 Time delay relay

1. The AQ4 power vent kit is equipped with a time delay relay. It is supplied with the time delay set at the (0.1) second position
2. If installing the AQ4 with standing pilot models 1600P or 425PN, no adjustment is required.
3. If installing the AQ4 with hydro ignition models 1600H or 425HN, move the adjuster on the time delay to the (2) second position. (Fig. 11B)
4. To access the time delay relay, unplug powervent and remove the electrical box cover on power vent motor. (Fig. 11A)

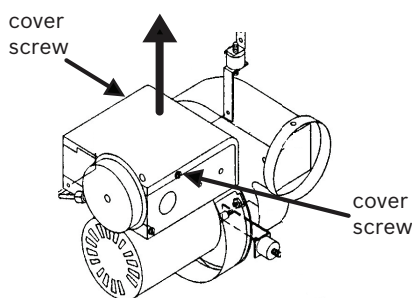

Fig. 11 Accessing the time delay relay

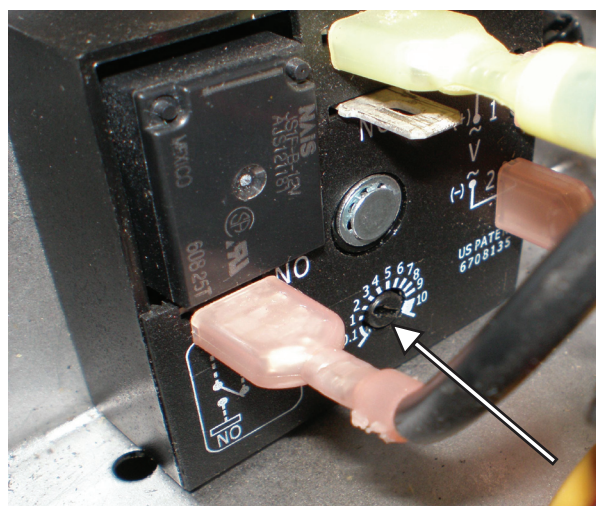

Fig. 11B Time delay relay positioning

3.1.2 Verifying proper operation of powervent

It is important to verify proper operation of the power vent motor before commissioning the system:

1. Slowly turn on cold water supply and check for any leaks at newly installed flow switch and piping.
2. Plug power vent motor into 120VAC outlet.

3. With the gas supply to the water heater turned off (see water heater manual) turn on a hot water tap. The power vent motor should come on. Verify the back-draft flapper is open and air is being blown out of the power vent hood. If not, see the troubleshooting tips in Chapter 5.
4. Turn off hot water tap.

Note: The AQ4 power vent fan motor is equipped with a 45 second post purge cycle. The fan motor should continue to run for this length of time after the hot water flow has been shut off.

5. Open gas supply to the water heater and follow the lighting instructions in water heater installation manual.

3.1.2 Draft test

1. Operate the water heater by running hot water. Check for proper combustion and ensure there is no spillage by holding a recently extinguished match or other visible smoke source in front of the draft diverter. The smoke from the extinguished match should be quickly sucked into the opening and up the exhaust venting. If the smoke is blown back, there is a blockage in the vent or the vent motor is not operating properly.

3.1.3 Safety interlock test

1. Open the gas supply to the water heater.
2. Block the back draft flapper from opening from the outside.



CAUTION: The metal of the back draft flapper will be hot when conducting this test.

3. Turn on the hot water supply to allow the burner to activate. Hot flue gasses will spill from the draft diverter momentarily. In less than three (3) minutes, the linear spillage switch should trip, opening the the heater safety circuit and halting the flow of gas to the heater.

NOTE: If spillage switch does not shut off the gas, check that you have made the proper safety circuit connections. If the switch still does not trip, contact Bosch Water Heating.

4. After the burners shut off, turn off hot water supply and wait 2-3 minutes...then push the reset button on the linear spillage switch.
5. Depending on model, light the pilot or run hot water and repeat Safety Interlock Test, (Step 1-4)
6. Ensure back draft flapper moves freely and closes properly once test is complete.

4 Maintenance

The vent system must be inspected at regular 3-month intervals. Points of inspection are as follows:

1. Screened opening of the vent hood should be free from foreign material and cleaned as necessary.
2. Check all vent system connections for leakage and reseal where needed with high temperature silicone sealant. If any vent pipe component shows signs of deterioration, replace immediately.
3. Inspect for proper closure of the back draft flapper accessory. If the flapper does not properly close, there is a risk of freezing air coming across the heat exchanger which may cause the pipes inside to freeze and burst. This condition is not covered by the water heater warranty. See Fig. 11A for a properly closed back-draft flapper.
4. Conduct safety interlock test and operation of backdraft flapper once a year (Chapter 3.1.3).

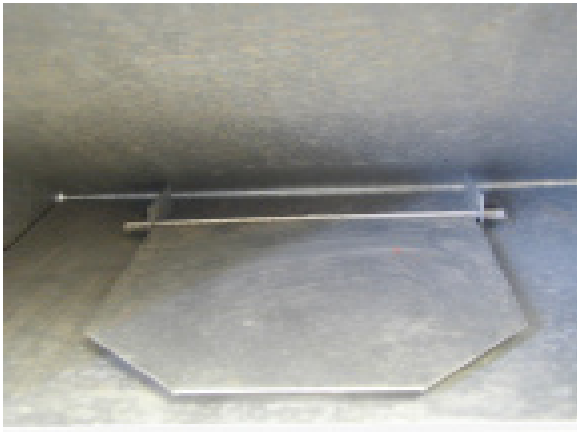

Fig. 11A Properly closed backdraft flapper



Fig. 11B Improperly closed backdraft flapper

5 Troubleshooting

5.1 Introduction

Many of the questions customers ask regarding operation of this unit can be answered by following the troubleshooting steps outlined below. Visit our website at www.boschhotwater.com for more detailed troubleshooting. For best results, perform each step before proceeding to the next.

5.2 Power vent motor runs all the time or intermittently without water flow

1. The power vent motor is flow switch activated. If the internal paddle inside the flow switch is jammed, it may constantly send a signal to turn on the fan. Shut off water supply to heater and drain. Remove flow switch from water heater piping by removing clips on both ends. Flush water through both ends of flow switch to free up internal paddle and clear debris. After flushing, shake flow switch up and down. The internal paddle should be heard moving freely back and forth.
2. Large amounts of water demand can create pressure drops throughout the plumbing. This may allow for movement of the power vent flow switch and activate the fan. Activated sprinkler systems or flushed toilets are common causes for this symptom. Consult a plumbing professional to correct unintentional water flow through the heater.
3. In buildings with excessively high water pressure, a condition known as “water hammer” may exist. This condition is caused by a combination of high water pressure and the abrupt closing of a faucet valve or internal washer/toilet valve. This instant change in flow results in an instant change in the internal pressures in the pipe, which then sends a shock wave through the pipe. This physical shock will shake, rattle or cause a loud bang in the plumbing which is referred to as “water hammer.” Such a shock wave may cause movement of the power vent flow switch which will activate the fan. Consult a plumbing professional for the use of a pressure reducing valve, expansion tank or water hammer arrestor to combat this condition.

5.3 Pilot will not stay lit when manually lit (1600P and 425PN) or will not spark automatically with hot water flow (1600H and 425HN)

1. Check the linear safety spillage switch reset button to see if it is tripped (See Section 2.6). Overheating or loss of power to the unit will trip the safety spillage switch and stop the flow of gas.
2. Check the entire pilot safety circuit (including the safety spillage switch) for loose or dirty connections (See Fig 8). Clean any corrosion evident with a pencil eraser or light sandpaper.
3. Pilot flame is weak or yellow. Consult water heater installation manual for instructions on cleaning the pilot assembly.

5.4 Spark but pilot will not light (1600H and 425HN only)

1. Check time delay relay for proper setting. See Section 3.1.1. Set time delay relay adjuster to the (2) second position for 1600H and 425HN only. If the pilot will not consistently light, move adjuster to the (3) second position and to (4) second position if needed. DO NOT exceed position (4). Complete safety interlock test after changing setting. See Section 3.1.3.

5.5 Pilot and/or burners go out during hot water use

1. Inspect entire vent system for blockage or obstruction. Ensure the back draft flapper installed on the power vent hood swings freely.
2. Verify power vent fan operates with water flow. If not, verify wire connection from flow switch to fan motor. Clean cold water inlet filter and verify flow rate through the water heater is adequate enough to activate the flow switch. If flow rate is more than 0.5 GPM, the flow switch may be defective and should be replaced.
3. If heater is newly installed, verify power vent fan motor is not installed backwards (See Fig 4).
4. Ensure power vent motor is mounted as close as possible to the VH1-4 vent hood. Mounting the power vent motor directly on top of or close to the water heater, may result in lifting flames and pilot outages. Vent pipe length must be at least 2 feet.

5.6 Noise when power vent motor is running

1. Ensure power vent motor is mounted level with motor shaft horizontal to prevent premature motor bearing wear.
2. Ensure power vent motor is mounted using the supplied vibration mounts to prevent premature motor bearing wear.
3. Remove vent pipe connection from water heater to power vent motor. Inspect internal fan wheel for broken fins. If any damage is evident, order online or call Technical Support (800) 642-3111 for a replacement wheel kit.

6 One Year Limited Warranty

General

The vent kit is warranted by the Manufacturer (TJERNLUND) through Bosch Thermotechnology Corp. Bosch Thermotechnology will furnish a replacement part which fails in normal use and service within the applicable periods specified below, in accordance with the terms of this warranty. The Bosch Thermotechnology replacement will be warranted for the unexpired portion of the original warranty. This warranty will be valid only for vent kits in possession of the original purchaser.

The Warranty Terms

If any vent kit component fails within one (1) year after the original installation and operation, Bosch Thermotechnology will furnish a replacement component. However, if the vent kit is installed in other than a single family dwelling, the warranty is limited to thirty (30) days from date of original installation and operation.

Exceptions

This warranty will not apply:

1. to defects or malfunctions resulting from failure to properly install, operate or maintain the unit in accordance with the printed instructions provided;
2. to damage or abuse, accident, neglect or other acts of nature;
3. to failure of the vent motor resulting from the operation of the vent kit in a corrosive atmosphere;
4. to defects or damage caused by any attachment or modification, including any energy-saving device.

Shipping costs:

In addition to supplying the replacement part(s), Bosch Thermotechnology will provide ground service delivery for these parts. Expedited or upgraded shipping will be charged to the customer.

Service Labor Costs

This warranty does not cover any labor costs associated with service, removal or re-installation of part(s). All such costs must be borne by the Purchaser. Additionally, this warranty does not cover any labor costs associated with service, removal or re-installation of the original vent kit or a replaced vent kit.

How to Make a Claim

Any claim for warranty parts should be made to your local dealer, distributor or to Bosch Thermotechnology. If Bosch Thermotechnology, please contact the Technical Support Department:

BOSCH THERMOTECHNOLOGY CORPORATION

340 Mad River Park
 Waitsfield, VT 05673
 Phone: 800-642-3111
www.boschhotwater.com

In most cases, the dealer or distributor will be able to promptly honor your claim and subsequently notify Bosch Thermotechnology. However, all replacements are made subject to validation by Bosch Thermotechnology of in-warranty coverage. The damaged or defective item must be made available in exchange for the replacement.

Miscellaneous

No one is authorized to make any other warranties on behalf of Bosch Thermotechnology. It is expressly understood that the replacement warranty of Bosch Thermotechnology shall be in lieu of any and all other warranties, express or implied, including warranties of merchantability or fitness for a particular use or purpose, and further that Bosch Thermotechnology shall not be liable for any loss or damage directly or indirectly arising from the use of the vent kit, or for any consequential damages arising from such use.

Bosch Thermotechnology sole liability with respect to any defect shall be for the replacement of the defective part(s). Some states do not allow such limitations and exclusions, so the above may not apply to you.

This warranty gives specific legal rights. You may also have other rights which vary from state to state.

7 Wiring diagram

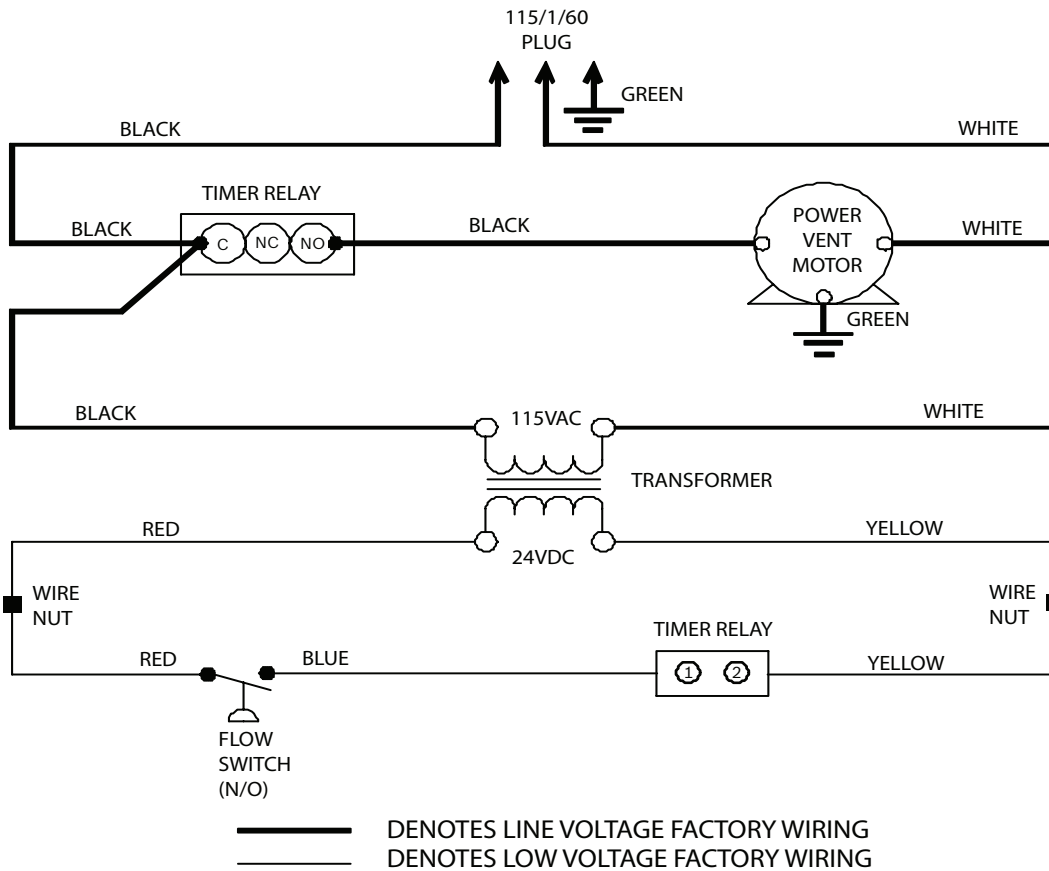
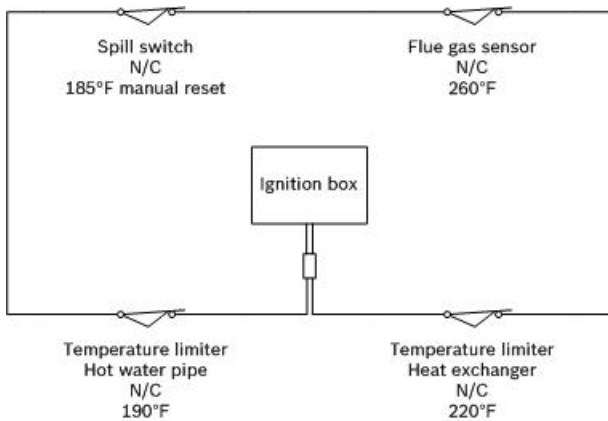
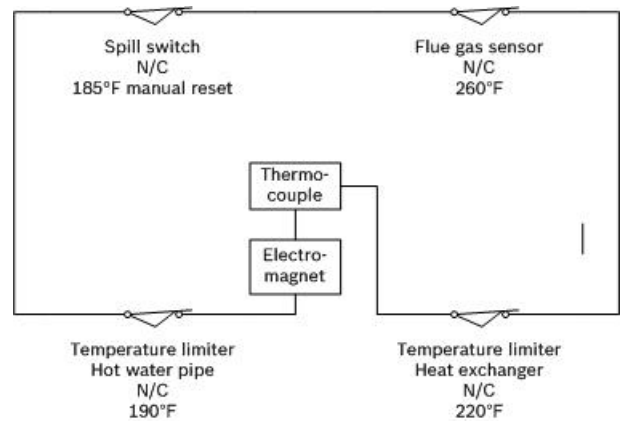

Fig. 12 Fan wiring diagram



425HN and 1600H wiring



425PN and 1600P wiring

Fig. 13 Safety circuit wiring diagram

8 Vent hood mounting

1. Use scissors to detach template. Verify external vent hood installation clearances on page 5 (Fig. 1) are adhered to. Attach the vent hood mounting template to the interior of the wall the vent hood will be penetrating.
2. Verify that wall penetration will not come in contact with concealed wiring or plumbing. Using a 1/2" drill bit, drill two pilot holes where noted on the template. The drill bit must be long enough to penetrate to the building exterior.
3. Attach the template to the building exterior aligning the pilot holes on the template with the pilot holes drilled in step 2.
4. Using a reciprocating saw, cut an opening through the building siding, wall board, etc., following the lines of the template.
5. Slide the vent hood through the opening and fasten to exterior wall using provided screws.
6. Once power venter is completely installed and secured, apply a bead of exterior rated caulk between vent hood flange and exterior of building.

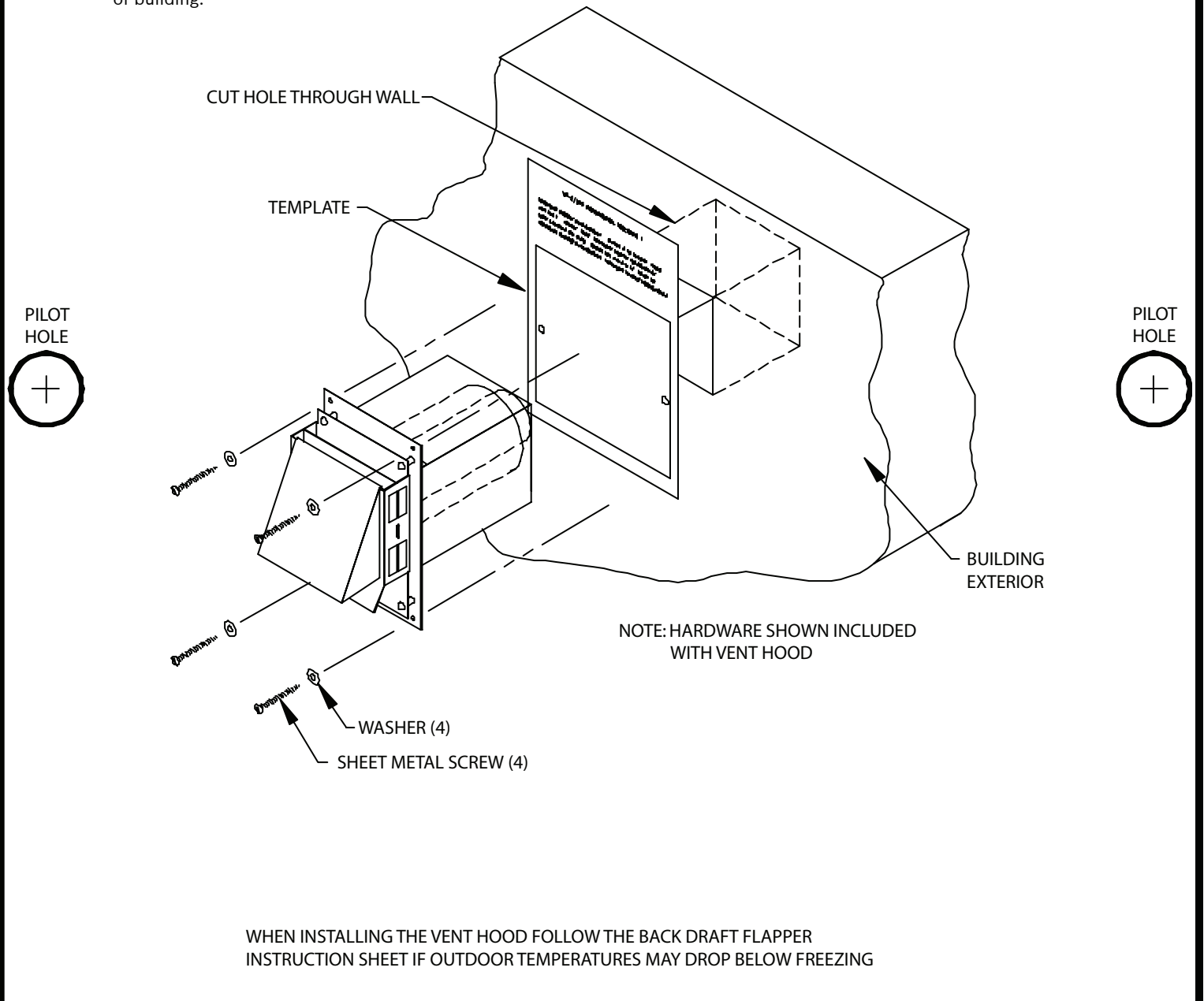

Fig. 14 Vent hood mounting template



BOSCH

Bosch Thermotechnology Corp.
50 Wentworth Avenue
Londonderry, NH 03053

Tel: 1-866-642-3198
Fax: 1-603-584-1681
www.boschpro.com